

UNIVERSAL SCROLL DENESTER

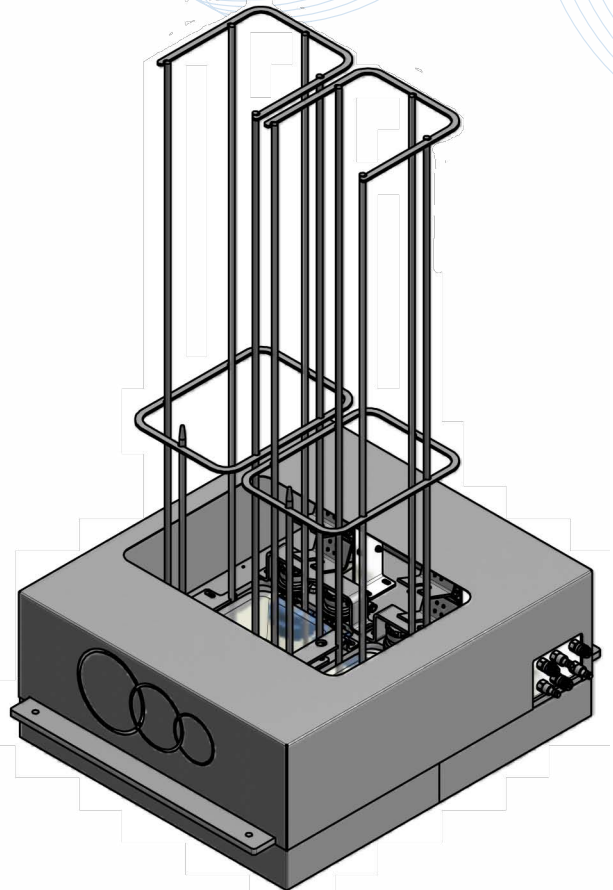

The universal scroll denester offers an innovative solution for a range of different process line applications. The denester is designed to place trays and lids on a conveyor belt by simply using curved rollers

This denester is able to process a variety of different types of trays through a simple adjustment, which can be performed by the user with minimal effort and tools. On every turn of the curved rollers the trays are placed on the conveyor belt. The four tray denesting system is able to process 200 trays per minute and with a large magazine, the unit has the ability to run at length without the need for reloading or human interference.



IMPACT AUTOMATION SOLUTIONS

Unit 2 • 52 Holker St Silverwater NSW 2128 Australia • T +61 (0)2 9648 6000 W www.impactautomation.com.au
Agents for: MGS, Lakewood Process Machinery, AZCO, A-One Packaging, Modular Packaging, and more

UNIVERSAL SCROLL DENESTER

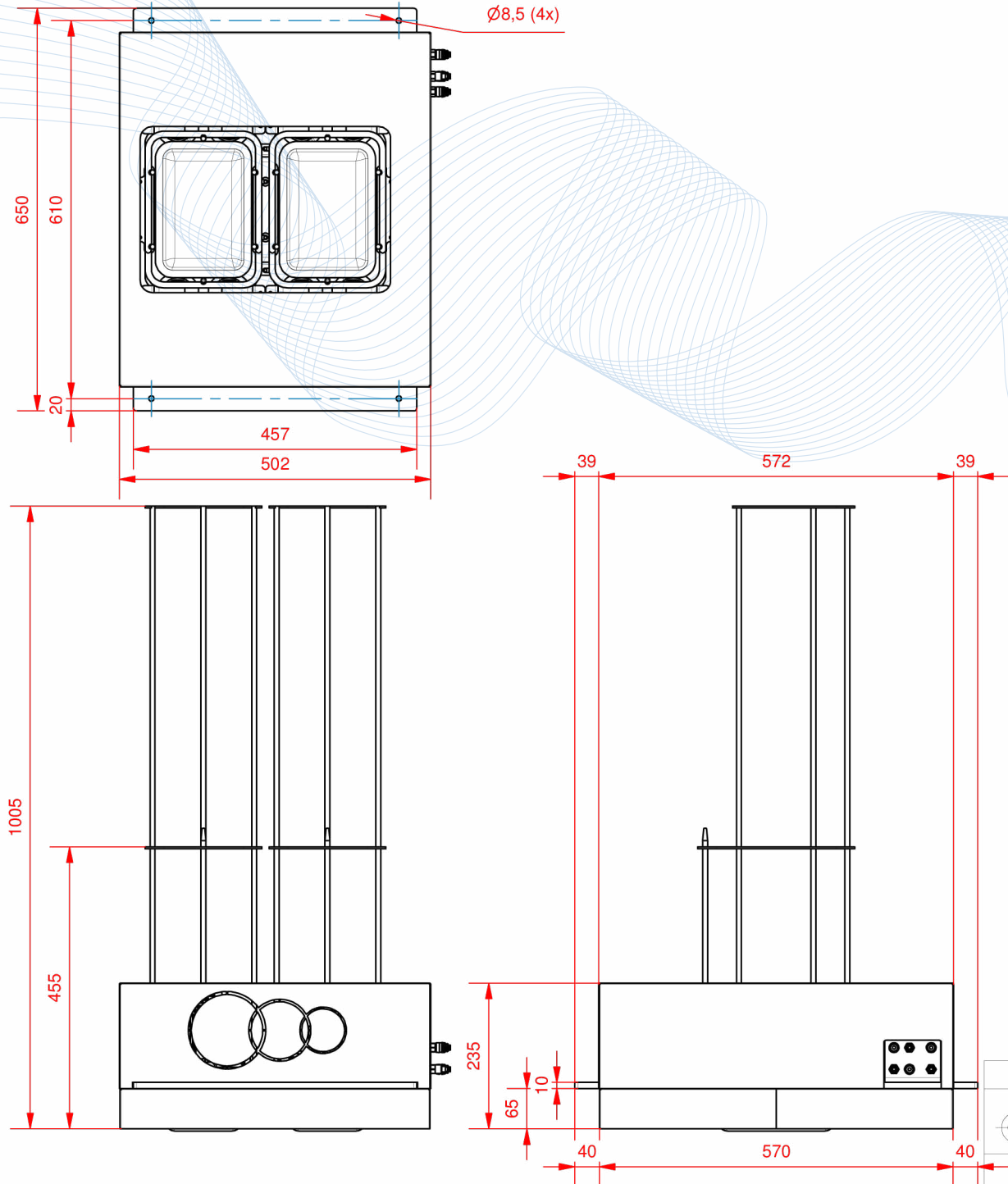

IMPACT AUTOMATION SOLUTIONS

Unit 2 • 52 Holker St Silverwater NSW 2128 Australia • T +61 (0)2 9648 6000 W www.impactautomation.com.au
Agents for: MGS, Lakewood Process Machinery, AZCO, A-One Packaging, Modular Packaging, and more